

Features and Benefits

- 513 full frames per sec**
 Fast frame rates ideal for ion signalling microscopy and adaptive optics
- TE cooling to -100°C**
 Critical for elimination of dark current detection limit
- OptAcquire**
 Optimize the highly flexible iXon3 for different application requirements at the click of a button
- Count Convert**
 Quantitatively capture and view data in electrons or incident photons. Real-time or post-processing
- RealGain™**
 Absolute EMCCD gain selectable directly from a linear and quantitative scale
- Spurious Noise Filters**
 Intelligent algorithms to filter clock induced charge events from the background. Real time or post-processing
- Cropped Sensor Mode**
 Specialised acquisition mode for continuous imaging with fastest possible temporal resolution
- iCam**
 The market-leading exposure time fast-switching software
- UltraVac™ *1**
 Critical for sustained vacuum integrity and to maintain unequalled cooling and QE performance, year after year
- Superior Baseline Clamp and EM stability**
 Quantitative accuracy of dynamic measurements
- Real Time Signal Averaging**
 Recursive and frame averaging functions for improved SNR
- Built-in C-mount compatible shutter (optional)**
 Easy means to record reference dark images

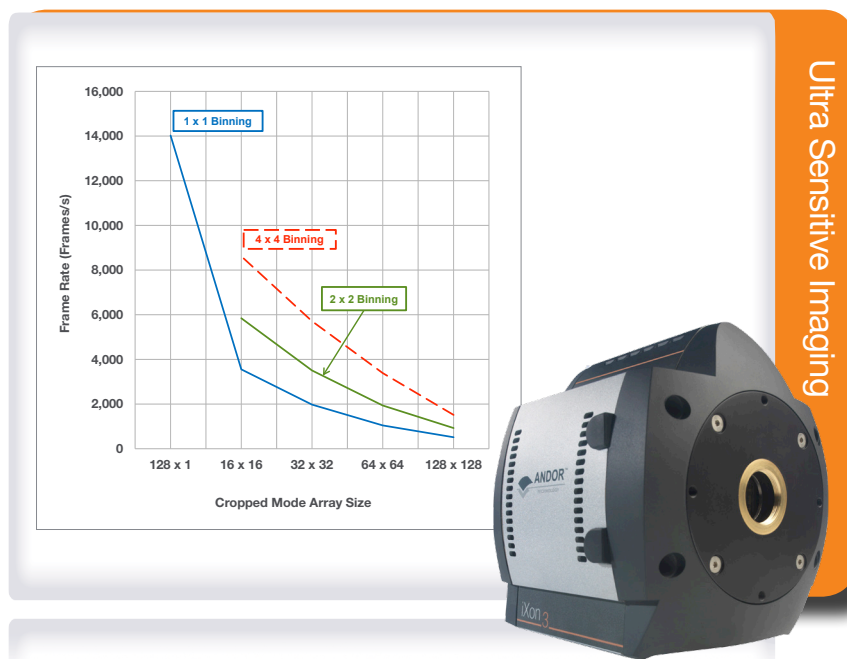

Lightning Speed & Ultra-Sensitivity

Andor's iXon3 860 back-illuminated EMCCD is designed for very rapid imaging of low light events, combining > 500 frames/sec with single photon detection capability and > 90% Quantum Efficiency. Thermoelectric cooling down to -100°C minimizes EM-amplified darkcurrent, whereas Andor's 'overclocked' vertical shift speeds minimize both clock induced charge noise and vertical smear during frame transfer.

The iXon3 860 benefits from an advanced set of user-requested features, including OptAcquire, Count Convert, Spurious Noise Filters & Signal Averaging. RealGain™ provides quantitative EM gain calibration.

Sub-millisecond biology is readily accessible through use of sub-array selection, pixel binning and Cropped Sensor Mode pushes frame rates to new extremes. The speed and sensitivity of the iXon3 860 also renders it ideal for adaptive optics.

Specifications Summary *2

Active pixels	128 x 128
Pixel size (W x H)	24 x 24 µm
Active area pixel well depth	160,000 e ⁻
Gain register pixel well depth	800,000 e ⁻
Maximum readout rate	10 MHz
Frame rate	513 - 14,025 fps
Read noise	< 1e ⁻ with EM gain
Maximum cooling	-100°C

System Specifications ^{*2}

Model number	860
Sensor options	#BV: Back Illuminated CCD, Vis optimized UVB: Back Illuminated CCD with UV coating
Active pixels	128 x 128
Pixel size	24 x 24 μm
Image area	3.1 x 3.1 mm with 100% fill factor
Minimum temperature, air cooled, ambient 20°C	-85°C
Recirculator liquid cooling, coolant @ 22°C, >0.75l/min	-95°C
Chiller liquid cooling, coolant @ 10°C, >0.75l/min	-100°C
Digitization	True 14 bit @ 10, 5, 3 & 1 MHz readout rate (optional 16-bit available @ 1 MHz)
Triggering	Internal, External, External Start, External Exposure, Software Trigger
System window type	#BV sensor: UV-grade fused silica, 'Broadband VIS-NIR', wedged UVB sensor: UV-grade fused silica, 'Broadband VUV-NIR', unwedged
Blemish specification	Grade 1 sensor (CCD60), as defined by the sensor manufacturer e2V (see www.e2v.com for further details)

Advanced Performance Specifications ^{*2}

Dark current and background events ^{*3,4}																
Dark current ($e^-/\text{pixel}/\text{sec}$) @ -85°C	0.002															
Spurious background (events/pix) @ 1000x gain and -85°C	0.05															
Active area pixel well depth	160,000 e^-															
Gain register pixel well depth ^{*5}	800,000 e^-															
Pixel readout rates	10, 5, 3, 1 MHz															
Read noise (e^-) ^{*6}	<table border="1"> <thead> <tr> <th></th> <th>Without Electron Multiplication</th> <th>With Electron Multiplication</th> </tr> </thead> <tbody> <tr> <td>10 MHz through EMCCD amplifier</td> <td>48</td> <td>< 1</td> </tr> <tr> <td>5 MHz through EMCCD amplifier</td> <td>40</td> <td>< 1</td> </tr> <tr> <td>3 MHz through EMCCD amplifier</td> <td>28</td> <td>< 1</td> </tr> <tr> <td>1 MHz through EMCCD amplifier</td> <td>18</td> <td>< 1</td> </tr> </tbody> </table>		Without Electron Multiplication	With Electron Multiplication	10 MHz through EMCCD amplifier	48	< 1	5 MHz through EMCCD amplifier	40	< 1	3 MHz through EMCCD amplifier	28	< 1	1 MHz through EMCCD amplifier	18	< 1
	Without Electron Multiplication	With Electron Multiplication														
10 MHz through EMCCD amplifier	48	< 1														
5 MHz through EMCCD amplifier	40	< 1														
3 MHz through EMCCD amplifier	28	< 1														
1 MHz through EMCCD amplifier	18	< 1														
Linear absolute Electron Multiplier gain	1 - 1000 times via RealGain™ (calibration stable at all cooling temperatures)															
Linearity ^{*7}	Better than 99%															
Vertical clock speed	0.0875 to 0.45 μs (variable)															

Frame Rates (Standard Mode) ^{*8}

Binning	Array size				
	128 x 128	64 x 64	32 x 32 & 128 x 32	16 x 16	128 x 1
1 x 1	513	943	1639	2500	4348
2 x 2	926	1588	2439	3333	-
4 x 4	1515	2272	3125	3704	-

Frame Rates (Cropped Mode) ^{*8}

Binning	Array size			
	64 x 64	32 x 32 & 128 x 32	16 x 16	128 x 1
1 x 1	1044	1975	3551	14025
2 x 2	1937	3503	5841	-
4 x 4	3385	5711	8620	-

Quantum Efficiency Curves ⁹⁹

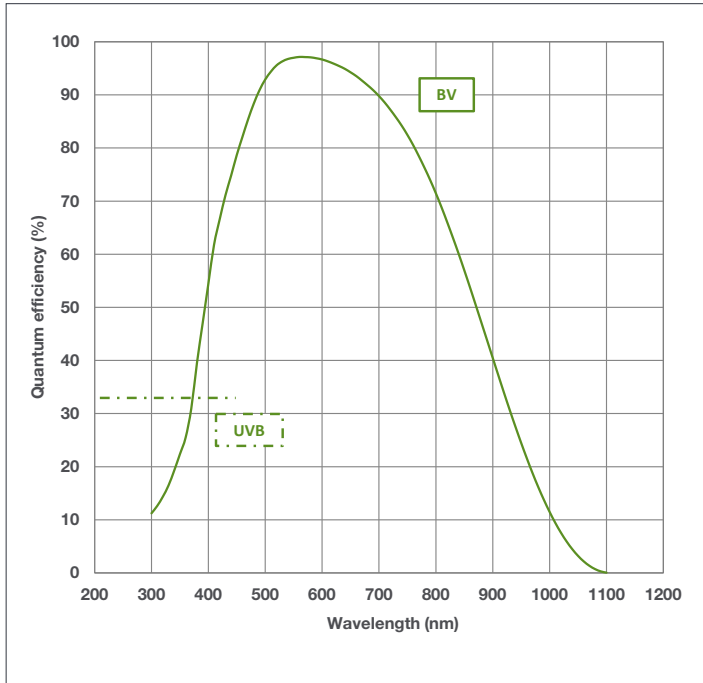

QE vs. Fluorophores Curve

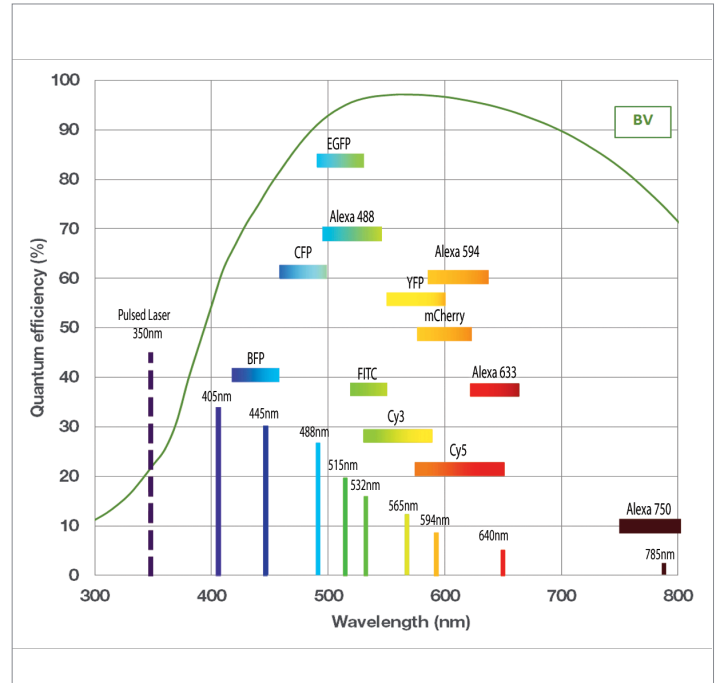

Application Image

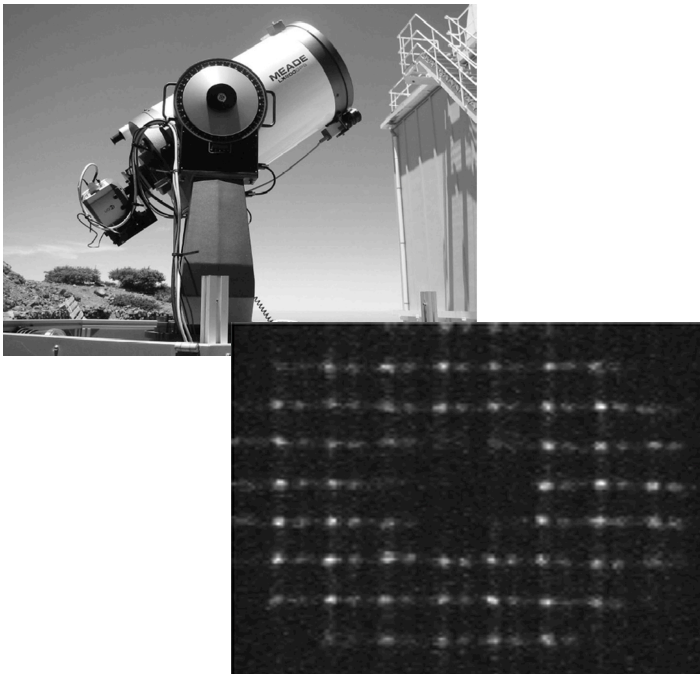

Slope Detection and Ranging (SLODAR) double star technique using the 860 model with 2 ms exposure time. The camera is shown at the European Southern Observatory (ESO) site at Cerro Paranal in Chile, mounted on a 40cm Schmidt-Cassegrain telescope and operated through Linux. The image shows an example Shack-Hartmann wavefront sensing frame.

Courtesy of Dr Richard Wilson, Centre for Advanced Instrumentation, University of Durham.

Application Image

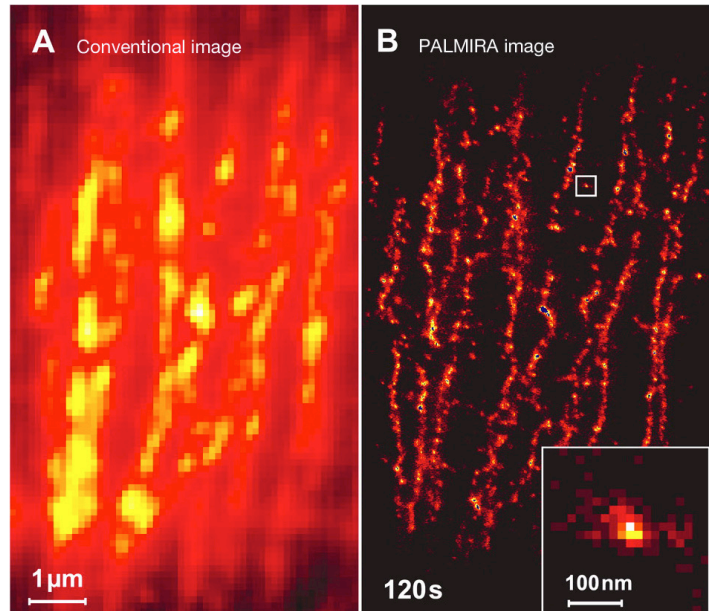

Conventional (A) and PALMIRA (B) super-resolution image of stained-tubulin intact PtK2 cell imaged with the high speed 860 model operating at 500 fps. PALMIRA is a single molecule super-resolution approach, employing an asynchronous acquisition mode in which readout and photo-switching are independently operated.

Courtesy of Alexander Egner and Stefan Hell, Department of NanoBiophotonics, Max Planck Institute for Biophysical Chemistry, Göttingen, Germany.

Creating The Optimum Product for You

How to customise the iXon₃ 860:

Step 1.

Simply select from the 2 digitisation options that best suit your needs from the selection opposite.

Step 2.

Please indicate if you require a shutter fitted to your iXon₃ 860.

Step 3.

The iXon₃ 860 comes with 2 options for sensor types. Please select the sensor which best suits your needs.

Step 4.

Please indicate alternative window option if required.

Step 5.

Please indicate which software and controller card you require.

Step 6.

For compatibility, please indicate which accessories are required.

Step 6.

The following accessories are available:

OPTOMASK Optomask microscopy accessory, used to mask unwanted sensor area during Cropped Sensor mode acquisition.

XW-RECR Re-circulator for enhanced cooling performance

ACC-XW-CHIL-160 Oasis 160 Ultra compact chiller unit

OA-CNAF C-mount to Nikon F-mount adapter

OA-COFM C-mount to Olympus adapter

OA-CTOT C-mount to T-mount adapter

DU-860 **D** -C **S** 0- **#BV**

example shown

Step 1.

Choose digitisation option

D: 10, 5, 3 & 1 MHz readout @ 14 bit
E: 10, 5, & 3 MHz readout @ 14 bit and 1 MHz @ 16 bit

Step 2.

Choose shutter option

S: Standard built-in mechanical shutter
0: No shutter

Step 3.

Choose sensor finish option

#BV: Standard back illuminated sensor
UVB: Back Illuminated sensor with UV coating

Step 4.

Select alternative camera window (optional)

The standard window has been selected to satisfy most applications. However, other options are available. The alternative camera window code must be specified at time of ordering.

To view and select other window options please refer to the '**Camera Windows Supplementary Specification Sheet**' which gives the transmission characteristics, product codes and procedure for entering the order. Further detailed information on the windows can be found in the Technical note – '**Camera Windows: Optimizing for Different Spectral Regions**'.

Step 5.

The iXon₃ 860 requires at least one of the following controller card and software options:

CCI-23 PCI Controller card.

CCI-24 PCIe Controller card.

Solis Imaging A 32-bit application compatible with 32 and 64-bit Windows (XP, Vista, 7 and 8) offering rich functionality for data acquisition and processing. AndorBasic provides macro language control of data acquisition, processing, display and export.

Andor SDK A software development kit that allows you to control the Andor range of cameras from your own application. Available as 32 and 64-bit libraries for Windows (XP, Vista, 7 and 8), compatible with C/C++, C#, Delphi, VB6, VB.NET, LabVIEW and Matlab. Linux SDK compatible with C/C++.

Andor iQ A comprehensive multi-dimensional imaging software package. Offers tight synchronization of EMCCD with a comprehensive range of microscopy hardware, along with comprehensive rendering and analysis functionality. Modular architecture for best price/performance package on the market.

Third party software compatibility

Drivers are available so that the iXon₃ range can be operated through a large variety of third party imaging packages. See Andor web site for detail: andor.com/software/

Product Drawings

Dimensions in mm [inches]

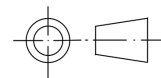

Third-angle projection

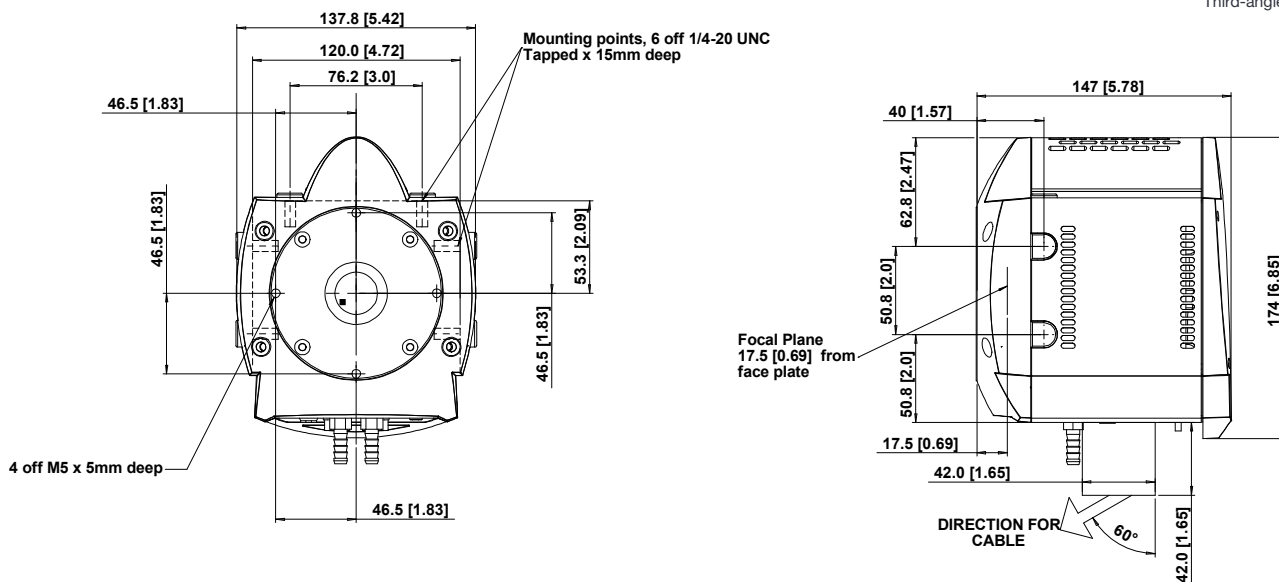

■ = position of pixel 1,1

Weight: 3.4 kg [7 lb 8 oz]

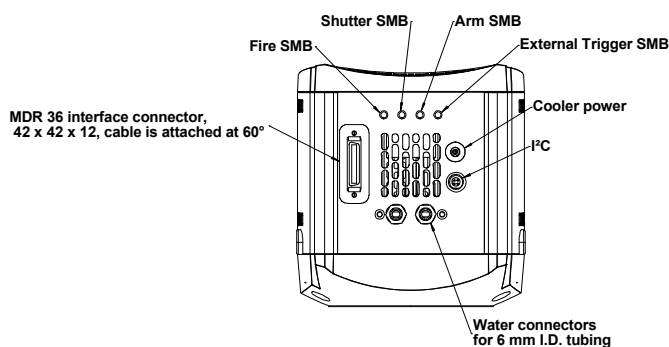

Connector panel

Connecting to the iXon₃

Camera Control

Connector type: PCI or PCIe

TTL / Logic

Connector type: SMB, provided with SMB - BNC cable

Fire (Output), Shutter (Output), Arm (Output), External Trigger (Input)

I²C connector

Compatible with Fischer SC102A053-130, pinouts as follow:

1 = I²C Clock, 2 = I²C Data, 3 = Ground, 4 = +5 Vdc

Minimum cable clearance required at rear of camera

90 mm

Typical Applications

Single Molecule Detection
Calcium Flux
Voltage Sensitive Dyes
Adaptive Optics
FRET
Fluorescence Correlation Spectroscopy (FCS)



Order Today

Need more information? At Andor we are committed to finding the correct solution for you. With a dedicated team of technical advisors, we are able to offer you one-to-one guidance and technical support on all Andor products. For a full listing of our local sales offices, please see: andor.com/contact

Our regional headquarters are:

Europe

Belfast, Northern Ireland
Phone +44 (28) 9023 7126
Fax +44 (28) 9031 0792

Japan

Tokyo
Phone +81 (3) 3518 6488
Fax +81 (3) 3518 6489

North America

Connecticut, USA
Phone +1 (860) 290 9211
Fax +1 (860) 290 9566

China

Beijing
Phone +86 (10) 5129 4977
Fax +86 (10) 6445 5401

Items shipped with your camera:

- 1x PCI or PCIe controller card + SATA adapter
- 1x Controller card splitter/fly-lead (if required)
- 1x 3m iXon₃ detector cable
- 2x 2m SMB to BNC connection cables
- 1x Power supply with mains cable
- 1x Quick launch guide
- 1x CD containing Andor user manuals
- 1x Individual system performance booklet
- 1x Disposable ESD wrist strap

Footnotes: Specifications are subject to change without notice

1. Assembled in a state-of-the-art cleanroom facility, Andor's UltraVac™ vacuum process combines a permanent hermetic vacuum seal (no o-rings), with a stringent protocol to minimize outgassing, including use of proprietary materials.
2. Figures are typical unless otherwise stated.
3. The dark current measurement is averaged over the sensor area excluding any regions of blemishes.
4. Using Electron Multiplication (EM) the iXon₃ is capable of detecting single photons, therefore the true camera detection limit is set by the number of 'dark' background events. These background events consist of both residual thermally generated electrons and Clock Induced Charge (CIC) electrons (also referred to as Spurious Charge), each appearing as random single spikes that are well above the read noise floor. A thresholding scheme is employed to count these single electron events and is quoted as a probability of an event per pixel. Acquisition conditions are full resolution and max frame rate (10 MHz readout; frame-transfer mode; 0.1 μs vertical clock speed; x 1000 EM gain; 10 ms exposure; -85°C).
5. The EM register on CCD60 sensors has a linear response up to ~400,000 electrons and a full well depth of ~800,000 electrons.
6. Readout noise is for the entire system. It is a combination of sensor readout noise and A/D noise. Measurement is for Single Pixel readout with the sensor at a temperature of -75°C and minimum exposure time under dark conditions. Under Electron Multiplying conditions, the effective system readout noise is reduced to sub 1e⁻ levels.
7. Linearity is measured from a plot of counts vs exposure time under constant photon flux up to the saturation point of the system.
8. All measurements are made with 0.1 μs vertical clock speed. It also assumes internal trigger mode of operation.
9. Quantum efficiency of the sensor at 20°C, as supplied by the sensor manufacturer.

Recommended Computer Requirements:

- 3.0 GHz single core or 2.6 GHz multi core processor
- 2 GB RAM
- 100 MB free hard disc to install software (at least 1 GB recommended for data spooling)
- PCI 2.2 or PCIe slot
- 10,000 rpm SATA hard drive preferred for extended kinetic series
- Windows (XP, Vista, 7 and 8) or Linux

Operating & Storage Conditions

- Operating Temperature: 0°C to 30°C ambient
- Relative Humidity: < 70% (non-condensing)
- Storage Temperature: -25°C to 50°C

Power Requirements

- 110 - 240 VAC, 50/60 Hz



LIXon3860SS 0114 R1